

# Data Sheet

## Efficient Self-Checkout Solution

### U-SCAN Acclaim

#### *Self-checkout worthy of Acclaim*

Retailers today face increasing pressure to meet the demands of time-conscious shoppers who expect quick, frictionless checkout experiences. The U-SCAN Acclaim is a budget-friendly solution built to address these issues, providing retailers with a simple, efficient way to streamline the checkout process. Designed for businesses seeking core functionality, the U-SCAN Acclaim offers a no-frills self-checkout system that's intuitive and easy to use, eliminating shoppers' challenge of having to adapt to new systems just to utilize self-checkout. The compact design fits seamlessly into various store layouts, helping maximize space and optimize the customer flow. The U-SCAN Acclaim is the ideal solution for retailers looking to enhance the checkout experience while keeping operations efficient and cost-effective.

#### Key Features

- Streamlines checkout to enhance customer flow
- Provides core self-checkout features without complexity
- Offers consistent performance day in and day out
- Simplified integration reduces downtime and maintenance
- Fits easily into existing store configurations and layouts
- Offers powerful features at a budget-friendly price
- S3 compatibility ensures scalability with future enhancements

By offering essential functionality without unnecessary complexity, the U-SCAN Acclaim focuses on core features that allow retailers to deliver a smooth, reliable experience. Built to withstand the demands of busy retail environments, U-SCAN Acclaim offers durability and reliability, with minimal maintenance required. Despite its powerful features, Acclaim is a cost-effective solution, delivering excellent value for businesses looking to improve their

checkout experience without excessive costs. It's a scalable solution that can grow with your business, easily integrating with additional units as your needs evolve. Whether you have a single store or multiple locations, Acclaim is adaptable to your business's growth, offering a balance of simplicity and power that enhances the checkout experience, boosts customer satisfaction, and keeps operations running smoothly.



# S<sup>3</sup> Self Service Simplified

S3 solutions ensure that every time a customer chooses self-service, their experience remains familiar, consistent, and intuitive. This streamlined experience eliminates unnecessary learning curves, drives high adoption rates, and reduces friction often associated with complex in-store technologies, all while empowering customers to shop with confidence.

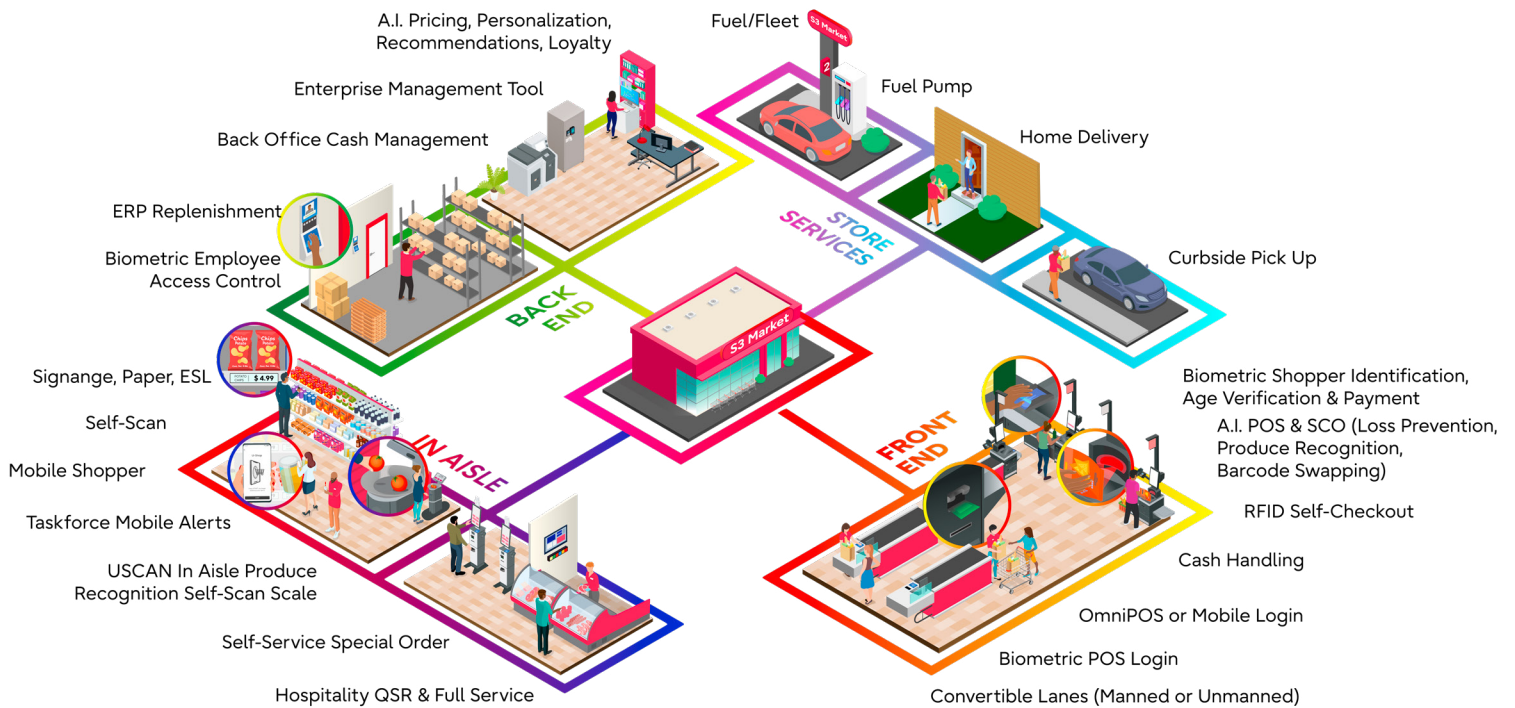

## Unified Commerce Solutions

As a key part of the S3 self-service product line, the U-SCAN Acclaim embodies the essence of unified commerce hardware solutions. Its minimalist design and compact footprint make it easy for retailers to implement a consistent self-service platform across their entire store environment.

With a familiar look and feel across all self-service touchpoints, customers can navigate the checkout process confidently and effortlessly, keeping the focus on shopping—not on managing complex technology.

In addition to minimizing the costs of managing store technology, S3 solutions reduce the need for interventions, freeing up staff for more valuable, revenue-generating tasks.

## S3 Compatibility



U-Scan



Integro



Taskforce



QSS



PalmSecure



U-Shop



Vision



Enterprise

# U-SCAN Acclaim Specifications

Dimensions (W x D x H)	348mm x 538mm x 1,864mm
Weight	Approx. 170kg
CPU	Type: Intel® 10th Generation Core™ i3-1110G4 Ice lake Chipset: Intel® Q470E Memory: 8GB LPDDR4X-4266 MHz RAM (onboard) expandable to 16GB Storage: 256 GB PCIe® NVMe™
LAN Ethernet	Intel® I219-LM GbE, Realtek RTL8153AH GbE WLAN: Intel® Wi-Fi 6 AX201 (2x2) and Bluetooth® 5 combo, non-vPro® Intel® Wi-Fi 6 AX201
Inputs/Outputs	3 SuperSpeed USB Type-A 10Gbps signaling rate 1 RJ-45 USB NIC 1 DC connector 2 USB 2.0 Type-A 1 SuperSpeed USB Type-C® 5Gbps signaling rate (27W USB Power Delivery; Alt Mode DisplayPort™) 1 140W data port 1 12v PUSB port 1 24v PUSB port
Display Options	HP Engage One Pro 19.5" Portrait, i3, 8Gb, 256Gb, Advanced Hub, 280w psu
Scanner Scale	Datalogic 9300 Bioptic
Printer	Epson M20 Printer internal
Lane Light	Acclaim EvoLight
Operating System	Windows10 LTSC 2019 and Windows10 LTSC 2021
SDK	Fujitsu Control Library (Optional)
Electrical Requirements	100-240V AC; 3A; 50/60 Hz
Temperature Operation	Operation: 32°F to 104°F (0°C to 40°C) Non-operating: 23°F to 122°F (-5°C to 50°C)
Humidity Operation	Operation: 10 to 90% non-condensing Non-operating: 8 to 95% non-condensing
Security Rating	Business Hours Enclosure
Compliance	UL, CSA, FCC, RoHS, REACH, CE

*Fujitsu Frontech North America reserves the right to change specifications without notice*

# U-SCAN Acclaim Specifications

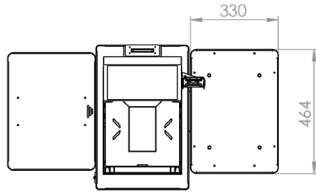

SINGLE SCALE SHELF

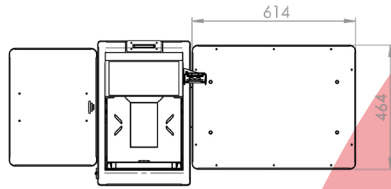

DOUBLE SCALE SHELF

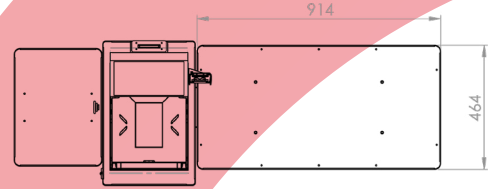

TRIPLE SCALE SHELF

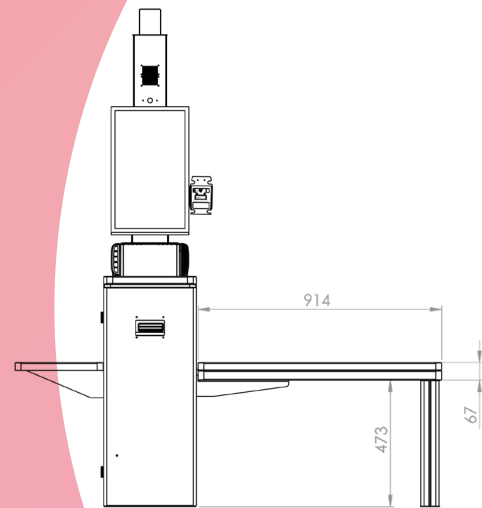
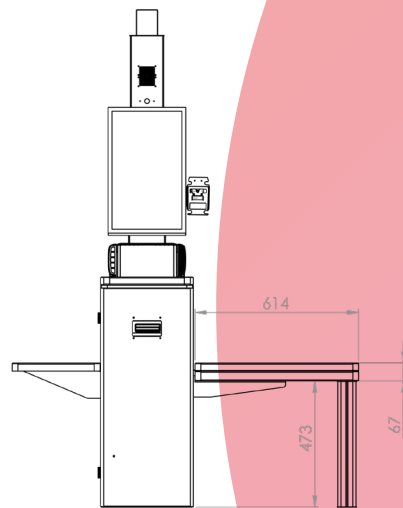
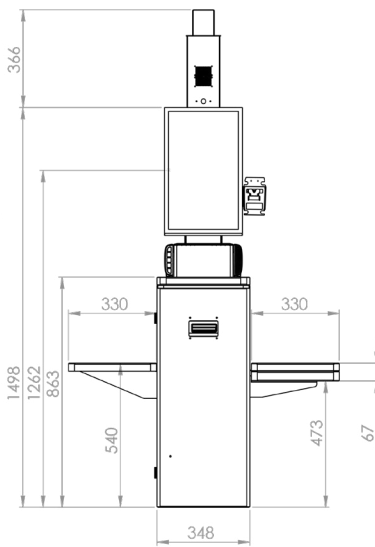

Fujitsu Frontech North America reserves the right to change specifications without notice

### Contact Fujitsu Frontech North America

Address: 36 Technology Dr, Suite #150, Irvine, CA, 92618

Phone: 877-766-7545

Email: [FFNA.sales@fujitsu.com](mailto:FFNA.sales@fujitsu.com)

Website: <https://fujitsufrontechna.com/acclaim>



©2025 Copyright Fujitsu Frontech North America Inc. All rights reserved. Fujitsu and the Fujitsu logo are registered trademarks. All other trademarks are the property of their respective owners. Statements herein are based on normal operating conditions and are not intended to create any implied warranty of merchantability or fitness for a particular purpose. Fujitsu Frontech North America Inc. reserves the right to modify, at any time without notice, these statements, our services, products, and their warranty and performance specifications.